

■ CRYSTALITE (XL)

- Strong, durable unit
- Surface mount & recessed versions
- Slim design
- Integrated switch
- 800 lumens

Internal View

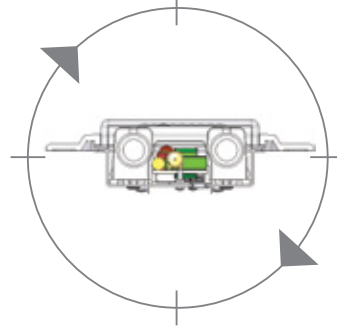

|| See technical specs overleaf >>>

REV 0



CRYSTALITE (XL)

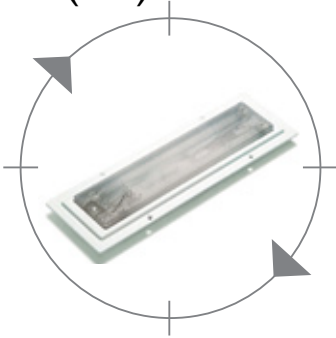

- Strong, durable unit - The Crystalite range has been designed to offer a strong, yet cost effective, light for use in a variety of applications, such as motorhomes, marine, vans and trucks.
- Surface mount & recessed versions - The Crystalite is available in both surface mount and recessed versions, both of which are supplied with a white fixing plate/surround which provides external mounting holes.
- Slim design - The slim design of this light allows for ultimate headroom preservation - the surface mounted unit is less than 34mm in height.
- Integrated switch - The chassis is fabricated from an aluminium sheet which secures both the inverter and the fluorescent tube. The tough, clear diamond patterned shade covers the chassis and also incorporates an on/off push switch.
- 800 lumens - Two 8W tubes emit 800 lumens of light.

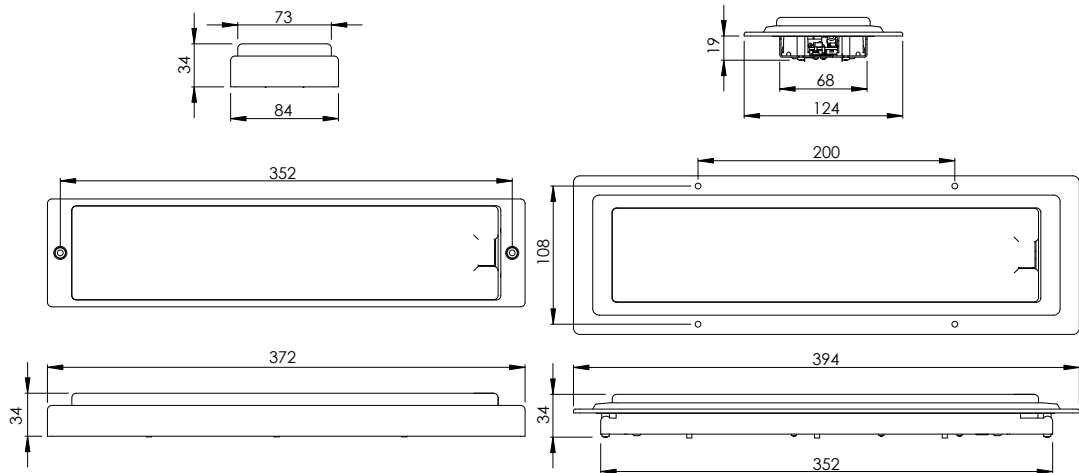

Specification

ALL DIMENSIONS HAVE A TOLERANCE OF +/- 1mm

CRYSTALITE (XL)

		XL16	XL16/2
Supply Voltage	VDC	12	24
Voltage Range	VDC	10-15	20-32
Average Current	A	0.85	0.55
Light Output	lm	800	800
Tube Watts	W	16	16
Weight	kg	0.44	0.44
Temp. Range	°C	-10 to +40	-10 to +40