

■ MICROLUX (SI3_2)

- Super-bright Power LEDs
- Multi-voltage (10-32V)
- Low energy consumption
- Easy to install low-profile unit
- Waterproof to IP67

Internal View

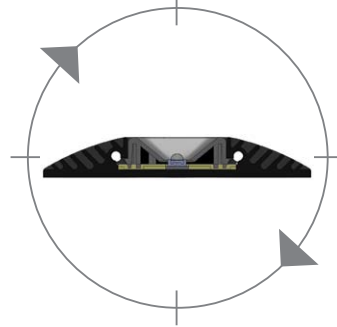

|| See technical specs overleaf >>>

REV 0



MICROLUX (SI3_2)



- Super-bright Power LEDs - The Microlux uses 2 CREE LEDs which emit 100 lumens each - the equivalent of a 20W halogen bulb.
- Multi-voltage (10-32V) - Engineered to suit a broad range of vehicles and their voltages, the circuitry can withstand changes in voltage and will provide a constant light output.
- Low energy consumption - The Microlux uses only 2W of energy.
- Easy to install low-profile unit - At just 15mm deep, this light can be fitted in a multitude of applications.
- Waterproof to IP67 - The Microlux is suitable for installation in a variety of environments, including refrigerated vehicles.

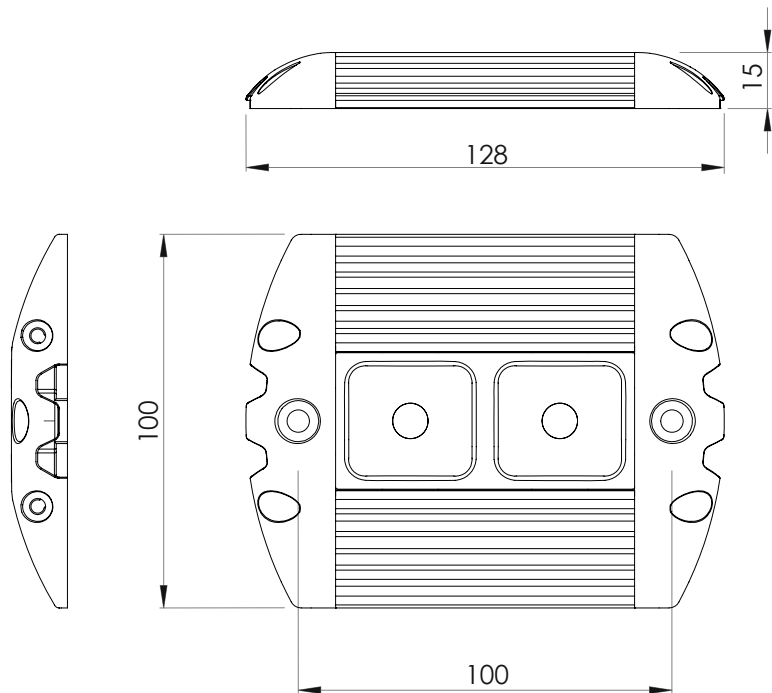

Specification

ALL DIMENSIONS HAVE A TOLERANCE OF +/-1mm

MICROLUX (SI3_2)

		SI3_2-1 MV	SI3_2-3 MV
Voltage Range	VDC	10-32V	10-32V
Average Current	A	12V = 0.22 24V = 0.12	12V = 0.45 24V = 0.24
Light Output	lm	200	340
LED Power	W	2 x 1.25W	2 x 2.5W
Weight	kg	0.165	0.165
Temp. Range	°C	-30 to +40	-30 to +40
Lux	lx	115 @ 1m 40 @ 2m	170 @ 1m 58 @ 2m