

■ NEBULA (SI5)

- Long life, high intensity LEDs
- 2 year guarantee
- Tough aluminium housing
- Integrated switch option
- Waterproof to IP66

Internal View

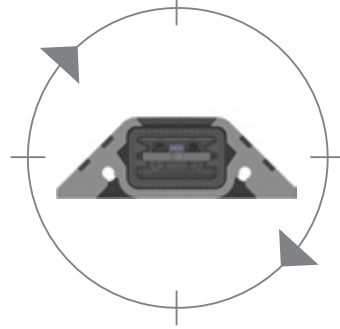

|| See technical specs overleaf >>>

REV 0



NEBULA (SI5)

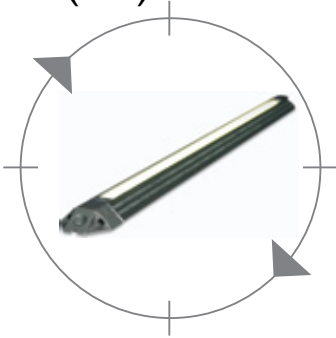

- Long life, high intensity LEDs - The Nebula incorporates the Orion LED strip light, which uses the latest in LED technology, offering optimum performance and extended life. The properties of these LEDs give greater luminosity, allowing us to offer a brighter unit whilst using fewer LEDs to maintain the low power draw. The unit is also now available with 48 and 72 LED strips.
- 2 year guarantee - The high quality properties of this unit have enabled us to offer you an extended guarantee.
- Tough aluminium housing - The Nebula is manufactured using a tough aluminium housing which protects a bright, low profile, surface mounted LED lighting solution, which is quick and easy to install.
- Integrated switch option - The Nebula can be switched remotely, or it is available with an integrated on/off rocker switch which fits neatly into the end cap.
- Waterproof to IP66 - The PCB, components and LEDs are completely encased within a polycarbonate extrusion, which protects against moisture ingress.

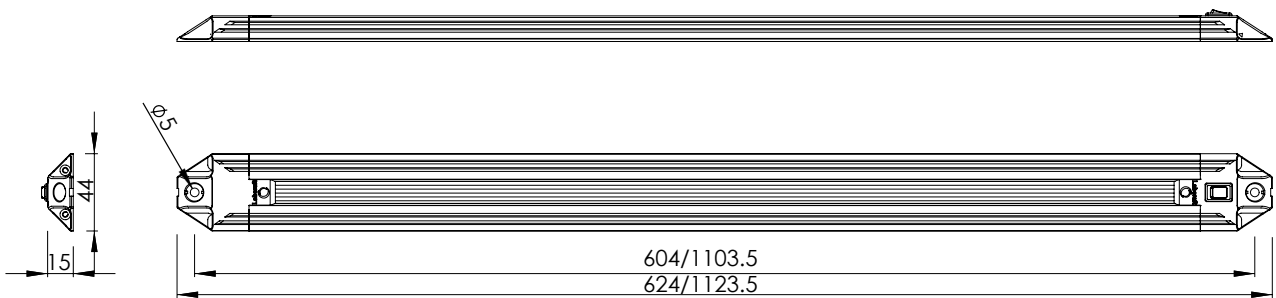

Specification

ALL DIMENSIONS HAVE A TOLERANCE OF +/- 1mm

NEBULA (SI5)

		SI5CW 500	SI5CW 500/2	SI5CW 1000	SI5CW 1000/2
Supply Voltage	VDC	12	24	12	24
Voltage Range	VDC	10-14	20-28	10-14	20-28
Average Current	A	0.18 max	0.11 max	0.36 max	0.22 max
Light Output	lm	192	192	384	384
LED Power	W	2.2W	2.2W	4.4W	4.4W
Weight	kg	0.46	0.46	0.82	0.82
Temp. Range	°C	-30 to +40	-30 to +40	-30 to +40	-30 to +40

REV 0

Calculations based on average LED values @ 13.28V (for 12V models) and @ 28V (for 24V)

E & OE