

■ **COACHLIGHT (CL)**

- Tough polycarbonate lens
- Low energy consumption
- Super bright light
- Surface or recessed

Internal View

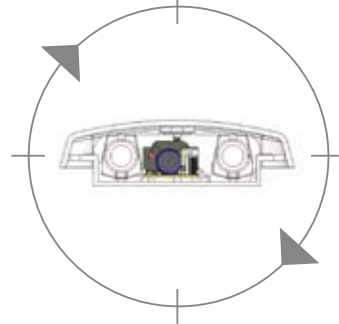

Available from:

|| See technical specifications overleaf >>>

COACHLIGHT (CL)



The COACHLIGHT series was originally designed to compliment Public Service Vehicles where appearance is of primary importance in both illuminated and rest mode. Since its development, the light has proved hugely successful due to its subtle looks and high level of reliability. Semi-recessed versions are available for use where headroom is restricted such as minibuses, and optional features include nightlights and high frequency operation to reduce radio interference. Examples of current applications include the MOD military ambulance fleet, minibuses, coaches, motorhomes and trucks. The base and lens are both constructed from high impact polycarbonate, reducing weight and improving strength. Installation is quick and simple via a number of pre-drilled holes in the base, and two screws in the lens.

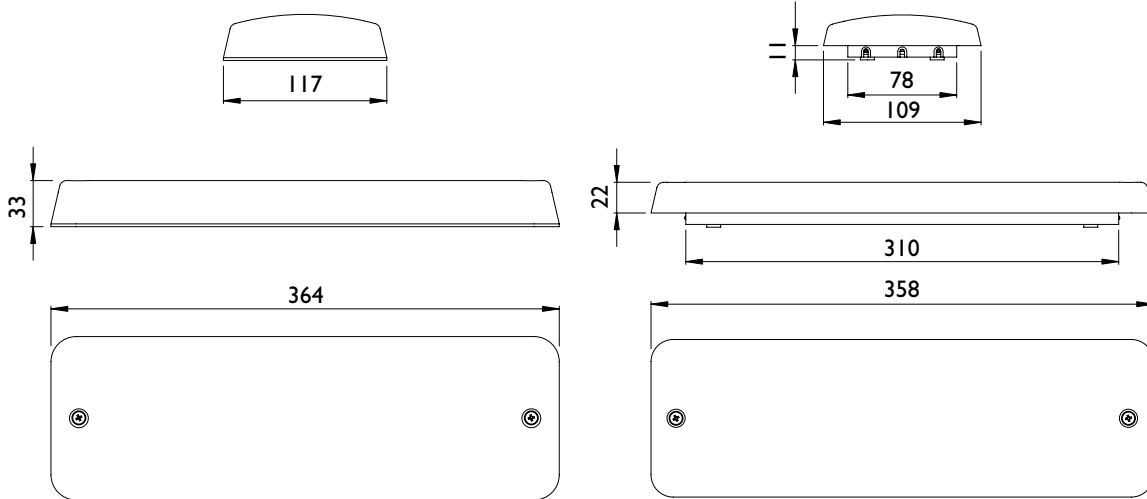

CLS MODELS (SURFACE MOUNTING)

CLR MODELS (RECESSED MOUNTING)

SPECIFICATION

ALL DIMENSIONS HAVE A TOLERANCE OF +/- 1mm

COACHLIGHT (CL)

Model No		CLR/CLS 16	CLR/CLS 16/2
Supply Voltage	Vdc	12	24
Voltage Range	Vdc	10 to 15	20 to 32
Average Current	A	1.38	0.69
Crest Factor		1.6	1.6
Frequency	KHz	20	20
Tube Watts	W	16W	16W
Lumens	Lm	800	800
Weight	Kg	0.36/0.4	0.36/0.4
Temp' Range	°C	-10 to +40	-10 to +40

E & OE