

■ **FLUSHLINE SERIES (CX)**

- Bright output
- Low energy
- Night/Trauma light option
- High frequency available

Internal View

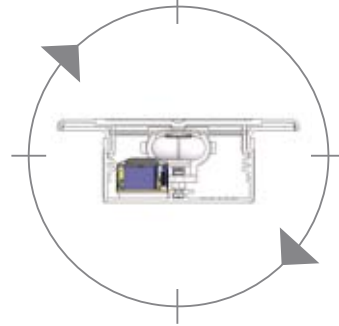

Available from:

|| See technical specifications overleaf >>>

FLUSHLINE SERIES (CX)



The FLUSHLINE from Labcraft is designed to meet the demand for a cost effective lighting system in vehicles with limited headroom or which require unobtrusive lighting. The chassis is extruded from high quality aluminium giving a rigid structure while keeping weight to a minimum. The opal diffuser is also extruded allowing the FLUSHLINE to be used for continuous lighting systems in addition to stand alone units. Maximum light output is achieved by a prismatic internal shade pattern which also helps to reduce glare by distributing the light more evenly. When installed, the FLUSHLINE protrudes only 5.5mm into the working space and requires merely 35mm recessing depth.

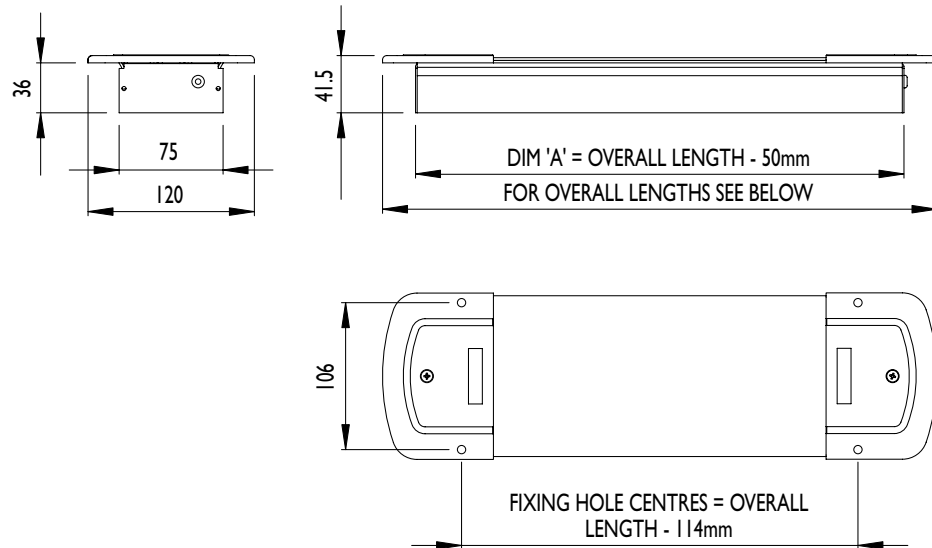

OVERALL LENGTHS: CX11 = 400mm CX18 = 780mm CX30 = 1085mm

SPECIFICATION

ALL DIMENSIONS HAVE A TOLERANCE OF +/- 1mm

FLUSHLINE
SERIES (CX)

| Model No | | CX11 | CX11/2 | CX18 | CX18/2 | CX30 | CX30/2 |
|-----------------|-----|------------|----------|------------|----------|------------|----------|
| Supply Voltage | Vdc | 12 | 24 | 12 | 24 | 12 | 24 |
| Voltage Range | Vdc | 10 to 15 | 20 to 32 | 10 to 15 | 20 to 32 | 10 to 15 | 20 to 32 |
| Average Current | A | 1.0 | 0.5 | 1.6 | 0.8 | 2.6 | 1.3 |
| Frequency | KHz | 20 | | 20 | | 20 | |
| Tube Watts | W | 11W | | 18W | | 30W | |
| Lumens | Lm | 890 | | 1100 | | 2200 | |
| Weight | Kg | 0.68 | | 1.18 | | 1.73 | |
| Temp. Range | °C | -10 to +40 | | -10 to +40 | | -10 to +40 | |

E & OE